

SECTION – A
(TOTAL MARKS = 75)

1. This question consists of 25 (TWENTY-FIVE) sub-questions (1.1 - 1.25) of ONE mark each.
(25 × 1 = 25)
- 1.1 In a series RLC circuit at resonance, the magnitude of the voltage developed across the capacitor
(A) is always zero
(B) can never be greater than the input voltage
(C) can be greater than the input voltage, however, it is 90° out of phase with the input voltage
(D) can be greater than the input voltage, and is in phase with the input voltage.
- 1.2 Two incandescent light bulbs of 40 W and 60 W rating are connected in series across the mains. Then
(A) the bulbs together consume 100 W
(B) the bulbs together consume 50W
(C) the 60 W bulb glows brighter
(D) the 40 W bulb glows brighter
- 1.3 A unit step voltage is applied at $t = 0$ to a series RL circuit with zero initial conditions.
(A) It is possible for the current to be oscillatory.
(B) The voltage across the resistor at $t = 0^+$ is zero.
(C) The energy stored in the inductor in the steady state is zero.
(D) The resistor current eventually falls to zero.
- 1.4 Given two coupled inductors L_1 and L_2 , their mutual inductance M satisfies
(A) $M = \sqrt{L_1^2 + L_2^2}$
(B) $M > \frac{(L_1 + L_2)}{2}$
(C) $M > \sqrt{L_1 L_2}$
(D) $M \leq \sqrt{L_1 L_2}$
- 1.5 A passive 2-port network is in a steady-state. Compared to its input, the steady state output can never offer
(A) higher voltage
(B) lower impedance
(C) greater power
(D) better regulation
- 1.6 A single-phase transformer is to be switched to the supply to have minimum inrush current. The switch should be closed at
(A) maximum supply voltage
(B) zero supply voltage

- (C) $\frac{1}{\sqrt{2}}$ maximum supply voltage
 (D) $\frac{1}{2}$ maximum supply voltage

1.7 It is desirable to eliminate 5th harmonic voltage from the phase voltage of an alternator. The coils should be short-pitched by an electrical angle of

- (A) 30° (C) 72°
 (B) 36° (D) 18°

1.8 Fig. shows the magnetization curves of an alternator at rated armature current, unity power factor and also at no load. The magnetization curve for rated armature current, 0.8 power factor leading is given by

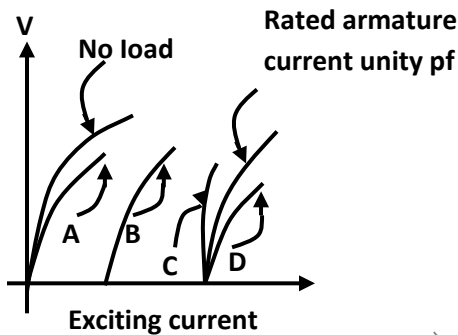

- (A) curve A (C) curve C
 (B) curve B (D) curve D

1.9 The core flux of a practical transformer with a resistive load

- (A) is strictly constant with load changes (C) increases as the square root of the load
 (B) increases linearly with load (D) decreases with increased load

1.10 X_d , X'_d and X''_d are steady state d-axis synchronous reactance, transient d-axis reactance and sub-transient d-axis reactance of a synchronous machine respectively. Which of the following statements is true?

- (A) $X_d > X'_d > X''_d$ (C) $X'_d > X''_d > X_d$
 (B) $X''_d > X'_d > X_d$ (D) $X_d > X''_d > X'_d$

1.11 A 50 Hz balanced three-phase, Y-connected supply is connected to a balanced three phase Y-connected load. If the instantaneous phase-a of the supply voltage is $V\cos(\omega t)$ and the phase-a of the load current is $I\cos(\omega t - \phi)$, the instantaneous three-phase power is

- (A) a constant with a magnitude of $V\cos\phi$
 (B) a constant with a magnitude of $(3/2)V\cos\phi$
 (C) time-varying with an average value of $(3/2)V\cos\phi$ and a frequency of 100 Hz.
 (D) time-varying with an average value of $V\cos\phi$ and a frequency of 50 Hz.
- 1.12 In the protection of transformers, harmonic restraint is used to guard against
 (A) magnetizing inrush current (C) lightning
 (B) unbalanced operation (D) switching over-voltages
- 1.13 A lossless radial transmission line with surge impedance loading
 (A) takes negative VAR at sending end and zero VAR at receiving end
 (B) takes positive VAR at sending end and zero VAR at receiving end
 (C) has flat voltage profile and unity power factor at all points along it
 (D) has sending end voltage higher than receiving end voltage and unity power factor at sending end.
- 1.14 The polar plot of a type-1, 3-pole, open-loop system is shown in Fig. The closed-loop system is

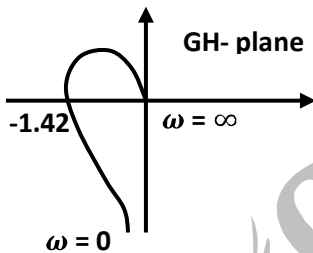

- (A) always stable
 (B) marginally stable
 (C) unstable with one pole on the right half s-plane
 (D) unstable with two poles on the right half s-plane
- 1.15 Given the homogeneous state-space equation $\begin{bmatrix} -3 & 1 \\ 0 & -2 \end{bmatrix} x$ the steady state value of $x_{ss} = \lim_{t \rightarrow \infty} x(t)$, given the initial state value of $x(0) = [10 \ -10]^T$, is
 (A) $x_{ss} = \begin{bmatrix} 0 \\ 0 \end{bmatrix}$ (C) $x_{ss} = \begin{bmatrix} -10 \\ 10 \end{bmatrix}$
 (B) $x_{ss} = \begin{bmatrix} -3 \\ -2 \end{bmatrix}$ (D) $x_{ss} = \begin{bmatrix} \infty \\ \infty \end{bmatrix}$

- 1.16 If an energy meter disc makes 10 revolutions in 100 seconds when a load of 450 W is connected to it, the meter constant (in rev/kWh) is
 (A) 1000 (C) 1600
 (B) 500 (D) 800
- 1.17 The minimum number of wattmeter (s) required to measure 3-phase, 3-wire balanced or unbalanced power is
 (A) 1 (C) 3
 (B) 2 (D) 4
- 1.18 In the single-stage transistor amplifier circuit shown in Fig. the capacitor C_E is removed. Then, the ac small-signal midband voltage gain of the amplifier
 (A) increases (C) is unaffected
 (B) decreases (D) drops to zero

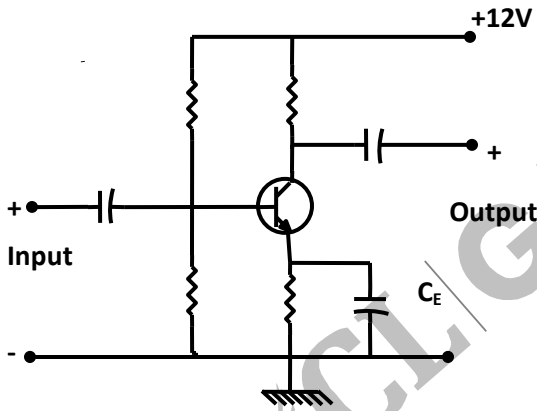

- 1.19 Among the following four, the slowest ADC (analog-to-digital converter) is
 (A) Parallel-comparator (i.e., flash) type (C) integrating type
 (B) successive approximation type (D) counting type
- 1.20 The output of a logic gate is “1” when all its inputs are at logic “0”. The gate is either
 (A) a NAND or an EX-OR gate (C) an AND or an EX-NOR gate
 (B) a NOR or an EX-OR gate (D) a NOR or an EX-NOR gate

1.21 The output f of the 4-to-1 MUX shown in Fig is

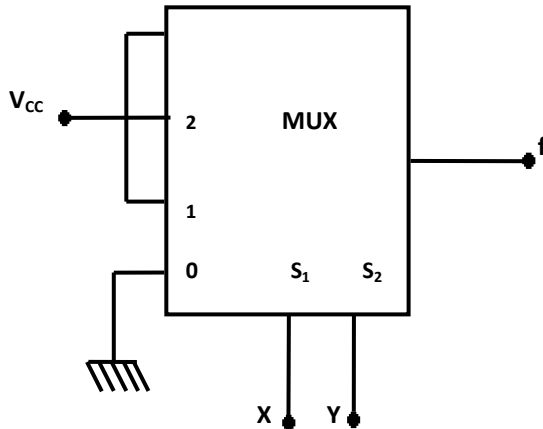

- (A) $\overline{xy} + x$ (C) $\overline{x} + \overline{y}$
 (B) $x + y$ (D) $xy + \overline{x}$
- 1.22 An op-amp has an open-loop gain of 10^5 and an open-loop upper cut-off frequency of 10 Hz. If this op-amp is connected as an amplifier with a closed-loop gain of 100, then the new upper cutoff frequency is
 (A) 10 Hz (C) 10 kHz
 (B) 100 Hz (D) 100 kHz
- 1.23 The main reason for connecting a pulse transformer at the output stage of a thyristor triggering circuit is to
 (A) amplify the power of the triggering pulse
 (B) provide electrical isolation
 (C) reduce the turn on time of the thyristor
 (D) avoid spurious triggering of the thyristor due to noise
- 1.24 AC-to-DC circulating current dual converters are operated with the following relationship between their triggering angles (α_1 and α_2).
 (A) $\alpha_1 + \alpha_2 = 180^\circ$ (C) $\alpha_1 - \alpha_2 = 180^\circ$
 (B) $\alpha_1 + \alpha_2 = 360^\circ$ (D) $\alpha_1 + \alpha_2 = 90^\circ$
- 1.25 In case of an armature controlled separately excited dc motor drive with closed-loop speed control, an inner current loop is useful because it
 (A) limits the speed of the motor to a safe value
 (B) helps in improving the drive energy efficiency

- (C) limits the peak current of the motor to the permissible value
 (D) reduces the steady state speed error

2. This question consists of TWENTY-FIVE sub-questions (2.1 - 2.25) of TWO marks each.

(25 × 2 = 50)

2.1 The electric field \vec{E} (in volts/ meter) at the point (1,1,0) due to a point charge of $+1\mu\text{C}$ located at (-1, 1, 1) (coordinates in meters) is

- (A) $\frac{10^{-6}}{20\sqrt{5}\pi\epsilon_0}(2i - k)$ (C) $\frac{-10^{-6}}{20\sqrt{5}\pi\epsilon_0}(2i - k)$
 (B) $\frac{10^{-6}}{20\pi\epsilon_0}(2i - k)$ (D) $\frac{-10^{-6}}{20\pi\epsilon_0}(2i - k)$

2.2 A connected network of $N > 2$ nodes has at most one branch directly connecting any pair of nodes. The graph of the network

- (A) must have atleast N branches for one or more closed paths to exist
 (B) can have an unlimited number of branches
 (C) can only have atmost N branches
 (D) can have a minimum number of branches not decided by N

2.3 Consider the star network shown in Fig. The resistance between terminals A and B with C open is 6Ω , between terminals B and C with A open is 11Ω , and between terminals C and A with B open is 9Ω . Then

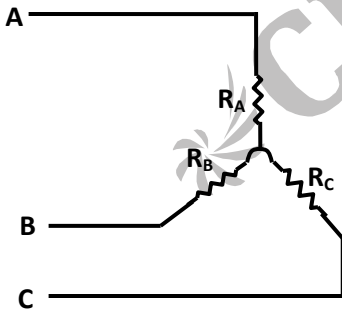

- (A) $R_A = 4\Omega, R_B = 2\Omega, R_C = 5\Omega$ (C) $R_A = 3\Omega, R_B = 3\Omega, R_C = 4\Omega$
 (B) $R_A = 2\Omega, R_B = 4\Omega, R_C = 7\Omega$ (D) $R_A = 5\Omega, R_B = 1\Omega, R_C = 10\Omega$

2.4 Given the potential function in free space to be $V(x) = (50x^2 + 50y^2 + 50z^2)$ volts, the magnitude (in volts/ meter) and the direction of the electric field at a point (1,-1, 1), where the dimensions are in meters, are

- (A) 100; $(i + j + k)$ (C) $100\sqrt{3}; [(-i - j - k)/\sqrt{3}]$
 (B) $100/\sqrt{3}; (i - j + k)$ (D) $100\sqrt{3} [(-i - j - k)/\sqrt{3}]$

- 2.5 The hysteresis loop of a magnetic material has an area of 5 cm^2 with the scales given as $1 \text{ cm} = 2 \text{ AT}$ and $1 \text{ cm} = 50 \text{ mWb}$. At 50 Hz , the total hysteresis loss is
- (A) 15 W (C) 25 W
(B) 20 W (D) 50 W
- 2.6 An electric motor with "constant output power" will have a torque-speed characteristic in the form of a
- (A) straight line through the origin (C) circle about the origin
(B) straight line parallel to the speed axis (D) rectangular hyperbola
- 2.7 A 3-phase transformer has rating of 20 MVA, 220 kV (star) - 33 kV (delta) with leakage reactance of 12%. The transformer reactance (in ohms) referred to each phase of the L.V. delta-connected side is
- (A) 23.5 (C) 18.5
(B) 19.6 (D) 8.7
- 2.8 A 75 MVA, 10 kV synchronous generator has $X_d = 0.4 \text{ p.u.}$ The X_d value (in p.u.) to a base of 100 MVA, 11 kV is
- (A) 0.578 (C) 0.412
(B) 0.279 (D) 0.44
- 2.9 A star-connected 440 V, 50 Hz alternator has per phase synchronous reactance of 10Ω . It supplies a balanced capacitive load current of 20 A, as shown in the per phase equivalent circuit of the given figure. It is desirable to have zero voltage regulation. The load power factor should be

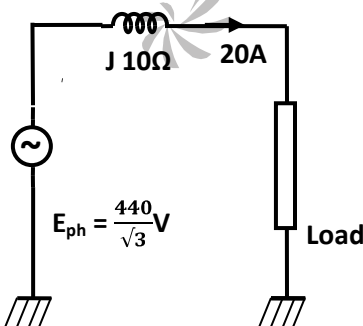

- (A) 0.82 (C) 0.39
(B) 0.47 (D) 0.92

2.10 A 240 V single-phase ac source is connected to a load with an impedance of $10\angle 60^\circ \Omega$. A capacitor is connected in parallel with the load. If the capacitor supplies 1250 VAR, the real power supplied by the source is

- (A) 3600 W (C) 2400 W
(B) 2880 W (D) 1200 W

2.11 A 50 Hz alternator is rated 500 MVA, 20 kV, with $X_d = 1.0$ per unit and $X'_d = 0.2$ per unit. It supplies a purely resistive load of 400 MW at 20 kV. The load is connected directly across the generator terminals when a symmetrical fault occurs at the load terminals. The initial rms current in the generator in per unit is

- (A) 7.22 (C) 3.22
(B) 6.4 (D) 2.2

2.12 Consider the model shown in Fig. of a transmission line with a series capacitor at its midpoint. The maximum voltage on the line is at the location

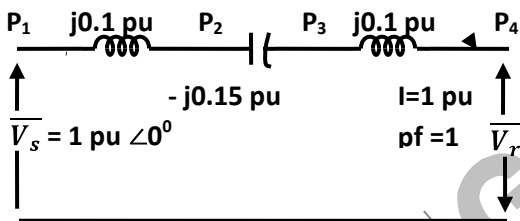

- (A) P_1 (C) P_3
(B) P_2 (D) P_4

2.13 A power system has two synchronous generators. The Governor-turbine characteristics corresponding to the generators are $P_1 = 50(50 - f)$, $P_2 = 100(51 - f)$. Where f denotes the system frequency in Hz, and P_1 and P_2 are, respectively, the power outputs (in MW) of turbines 1 and 2. Assuming the generators and transmission network to be lossless, the system frequency for a total load of 400 MW is

- (A) 47.5 Hz (C) 48.5 Hz
(B) 48.0 Hz (D) 49.0 Hz

2.14 The conductors of a 10 km long, single phase, two wire line are separated by a distance of 1.5m. The diameter of each conductor is 1 cm. If the conductors are of copper, the inductance of the circuit is

- (A) 50.0 mH (C) 23.8 mH
(B) 45.3 mH (D) 19.6 mH

2.15 Given the relationship between the input $u(t)$ and the output $y(t)$ to be

$$y(t) = \int_0^t (2 + t - \tau) e^{-3(t-\tau)} u(\tau) d\tau,$$

the transfer function $Y(s) / U(s)$ is

- (A) $\frac{2e^{-2s}}{s+3}$ (C) $\frac{2s+5}{s+3}$
 (B) $\frac{s+2}{(s+3)^2}$ (D) $\frac{2s+7}{(s+3)^2}$

2.16 The asymptotic approximation of the log-magnitude versus frequency plot of a minimum phase system with real poles and one zero is shown in Fig.P2.16. Its transfer functions is

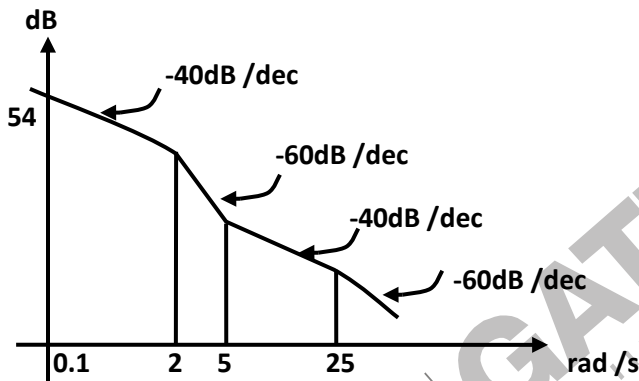

- (A) $\frac{20(s+5)}{s(s+2)(s+25)}$ (C) $\frac{20(s+5)}{s^2(s+2)(s+25)}$
 (B) $\frac{10(s+5)}{(s+2)^2(s+25)}$ (D) $\frac{50(s+5)}{s^2(s+2)(s+25)}$

2.17 A $100\mu\text{A}$ ammeter has an internal resistance of 100Ω . For extending its range to measure $500\mu\text{A}$, the shunt required is of resistance (in Ω)

- (A) 20.0 (C) 25.0
 (B) 22.22 (D) 50.0

2.18 Resistances R_1 and R_2 have, respectively, nominal values of 10Ω and 5Ω , and tolerances of $\pm 5\%$ and $\pm 10\%$. The range of values for the parallel combination of R_1 and R_2 is

- (A) 3.077Ω to 3.636Ω (C) 3.237Ω to 3.678Ω
 (B) 2.805Ω to 3.371Ω (D) 3.192Ω to 3.435Ω

2.19 For the oscillator circuit shown in Fig, the expression for the time period of oscillation can be given by (where $\tau=RC$)

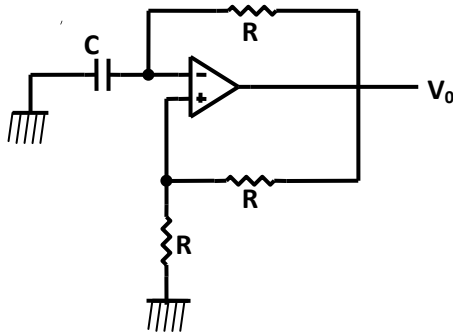

- (A) $\tau \ln 3$ (C) $\tau \ln 2$
 (B) $2\tau \ln 3$ (D) $2\tau \ln 2$

2.20 An Intel 8085 processor is executing the program given below.

```

MVI A, 10H
MVI B, 10H
BACK: NOP
      ADD B
      RLC
      JNC BACK
      HLT
  
```

The number of times that the operation NOP will be executed is equal to

- (A) 1 (C) 3
 (B) 2 (D) 4

2.21 A sample-and-hold (S/H) circuit, having a holding capacitor of 0.1 nF, is used at the input of an ADC (analog-to-digital converter). The conversion time of the ADC is 1 μ sec, and during this time, the capacitor should not lose more than 0.5% of the charge put across it during the sampling time. The maximum value of the input signal to the S/H circuit is 5V. The leakage current of the S/H circuit should be less than

- (A) 2.5 mA (C) 25.0 μ A
 (B) 0.25 mA (D) 2.5 μ A

2.22 An op-amp, having a slew rate of $62.8 \text{ V}/\mu\text{sec}$, is connected in a voltage follower configuration. If the maximum amplitude of the input sinusoidal is 10V , then the minimum frequency at which the slew rate limited distortion would set in at the output is

- (A) 1.0 MHz (C) 10.0 MHz
 (B) 6.28 MHz (D) 62.8 MHz

2.23 An n-channel JFET, having a pinch-off voltage (V_p) of -5V , shows a trans-conductance (g_m) of 1 mA/V when the applied gate-to-source voltage (V_{GS}) is -3V . Its maximum transconductance (in mA/V) is

- (A) 1.5 (C) 2.5
 (B) 2.0 (D) 3.0

2.24 A half-wave thyristor converter supplies a purely inductive load, as shown in Fig.P2.24. If the triggering angle of the thyristor is 120° , the extinction angle will be

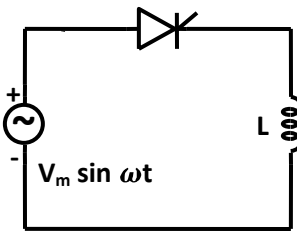

- (A) 240° (C) 200°
 (B) 180° (D) 120°

2.25 A single-phase full-bridge voltage source inverter feeds a purely inductive load, as shown in the figure, where T_1, T_2, T_3, T_4 are power transistors and D_1, D_2, D_3, D_4 are feedback diodes. The inverter is operated in square-wave mode with a frequency of 50 Hz . If the average load current is zero, what is the time duration of conduction of each feedback diode in a cycle?

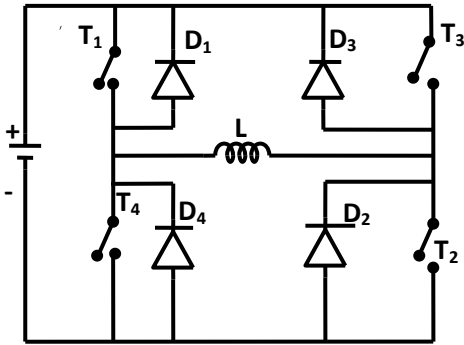

- (A) 5 msec
(B) 10 msec

- (C) 20 msec
(D) 2.5 msec

SECTION – B

(TOTAL MARKS = 75)

This section consists of TWENTY questions of FIVE marks each. ANY FIFTEEN out of them have to be answered.

3. Determine the resonance frequency and the Q-factor of the circuit shown in the figure. Data: $R = 10\Omega$, $C = 3\mu\text{F}$, $L_1 = 40\text{ mH}$, $L_2 = 10\text{ mH}$ and $M = 10\text{ mH}$.

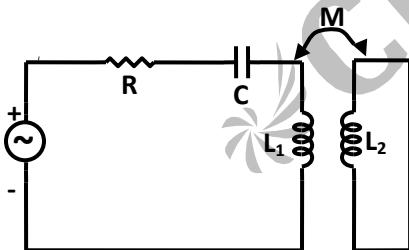

4. An ideal transformer has a linear B/H characteristic with a finite slope and a turns ratio of 1:1. The primary of the transformer is energized with an ideal current source, producing the signal i as shown in Fig. Sketch the shape (neglecting the scale factor) of the following signals, labeling the time axis clearly.

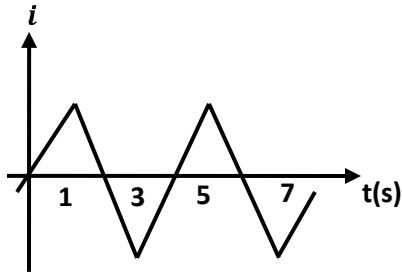

- (A) the core flux ϕ_{oc} with the secondary of the transformer open
 (B) the open-circuited secondary terminal voltage $v_2(t)$,
 (C) the short-circuited secondary current $i_2(t)$, and
 (D) the core flux ϕ_{sc} with the secondary of the transformer short-circuited.
5. Consider the voltage waveform v , shown in the figure. Find.
- the dc component of v ,
 - the amplitude of the fundamental component of v , and
 - the rms value of the ac part of v .

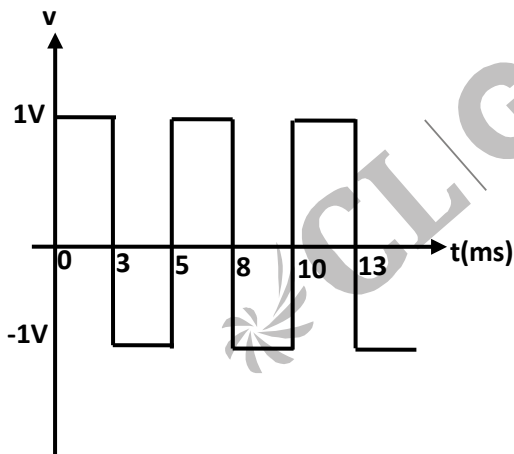

6. In a dc motor running at 2000 rpm, the hysteresis and eddy current losses are 500W and 200W respectively. If the flux remains constant, calculate the speed at which the total iron losses are halved.
7. A dc series motor is rated 230V, 1000 rpm, 80 A (refer to Fig.). The series field resistance is 0.11Ω , and the armature resistance is 0.14Ω . If the flux at an armature current of 20A is 0.4 times of that under rated condition, calculate the speed at this reduced armature current of 20A.



8. A 50 kW synchronous motor is tested by driving it by another motor. When the excitation is not switched on, the driving motor takes 800W. When the armature is short-circuited and the rated armature current of 10 A is passed through it, the driving motor requires 2500 W. On open-circuiting the armature with rated excitation, the driving motor takes 1800 W. Calculate the efficiency of the synchronous motor at 50% load. Neglect the losses in the driving motor.
9. Two identical synchronous generators, each of 100 MVA, are working in parallel supplying 100 MVA at 0.8 lagging p.f. at rated voltage. Initially the machines are sharing load equally. If the field current of first generator is reduced by 5% and of the second generator increased by 5%, find the sharing of load (MW and MVAR) between the generators. Assume $X_d = X_q = 0.8$ p.u., no field saturation and rated voltage across load. Reasonable approximations may be made.
10. A 132 kV transmission line AB is connected to a cable BC. The characteristic impedances of the overhead line and the cable are 400Ω and 80Ω respectively. Assume that these are purely resistive. A 250 kV switching surge travels from A to B.
- Calculate the value of this voltage surge when it first reaches C.
 - Calculate the value of the reflected component of this surge when the first reflection reaches A.
 - Calculate the surge current in the cable BC.
11. For the Y-bus matrix given in per unit values, where the first, second, third and fourth row refers to bus 1, 2, 3 and 4 respectively, draw the reactance diagram.

$$Y_{\text{bus}} = j \begin{bmatrix} -6 & 2 & 2.5 & 0 \\ 2 & -10 & 2.5 & 4 \\ 2.5 & 2.5 & -9 & 4 \\ 0 & 4 & 4 & -8 \end{bmatrix}$$

12. A synchronous generator is connected to an infinite bus through a lossless double circuit transmission line. The generator is delivering 1.0 per unit power at a load angle of 30° when a sudden fault reduces the peak power that can be transmitted to 0.5 per unit. After clearance of fault, the peak power that can be transmitted becomes 1.5 per unit. Find the critical clearing angle.
13. A single line-to-ground fault occurs on an unloaded generator in phase a positive, negative, and zero sequence impedances of the generator are $j0.25\text{p.u.}$, $j0.25\text{p.u.}$, and $j0.15\text{p.u.}$ respectively. The generator neutral is grounded through a reactance of $j0.05\text{p.u.}$ The prefault generator terminal voltage is 1.0p.u.
- Draw the positive, negative, and zero sequence networks for the fault given.
 - Draw the interconnection of the sequence networks for the fault analysis.
 - Determine the fault current.
14. A power system has two generators with the following cost curves:
 Generator 1: $C_1(P_{G1}) = 0.006P_{G1}^2 + 8P_{G1} + 350$ (Thousand Rupees/Hour)
 Generator 2: $C_2(P_{G2}) = 0.009P_{G2}^2 + 7P_{G2} + 400$ (Thousand Rupees/Hour)
 The generator limits are
 $100 \text{ MW} \leq P_{G1} \leq 650 \text{ MW}$
 $50 \text{ MW} \leq P_{G2} \leq 500 \text{ MW}$
 A load demand of 600 MW is supplied by the generators in an optimal manner. Neglecting losses in the transmission network, determine the optimal generation of each generator.
15. A unity feedback system has an open-loop transfer function of

$$G(s) = \frac{10000}{s(s+10)^2}$$

- Determine the magnitude of $G(j\omega)$ in dB at an angular frequency of $\omega=20$ rad/sec.
 - Determine the phase margin in degrees.
 - Determine the gain margin in dB.
 - Is the system stable or unstable?
16. Given the characteristic equation
- $$s^3 + 2s^2 + Ks + K = 0$$
- Sketch the root locus as K varies from zero to infinity. Find the angle and real axis intercept of the asymptotes, break-away/break-in points, and imaginary axis crossing points, if any.

17. For the ring counter shown in Fig, find the steady state sequence if the initial state of the counters is 1110 (i.e., $Q_3 Q_2 Q_1 Q_0=1110$). Determine the MOD number of the counter.

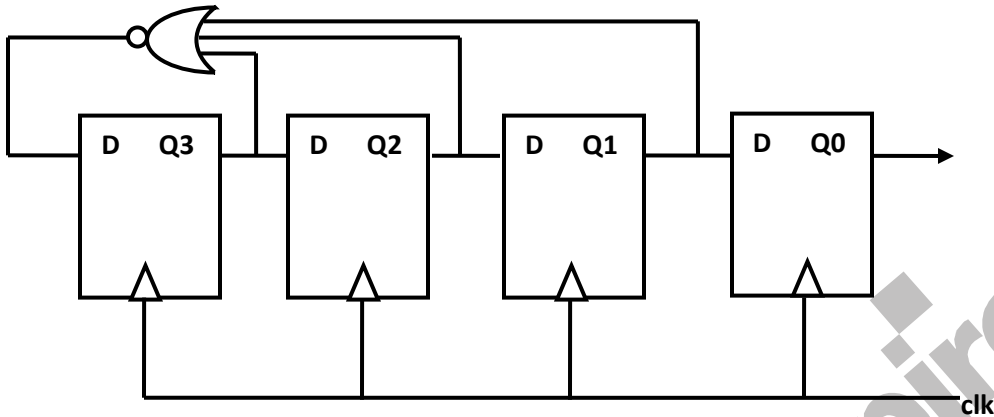

18. For the op-amp circuit shown in Fig, determine the output voltage v_o . Assume that the op-amps are ideal.

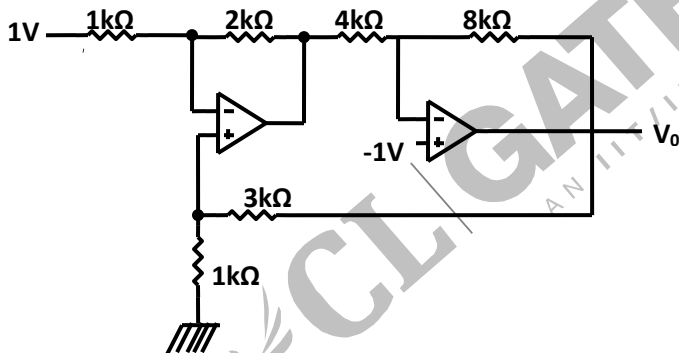

19. The transistor in the amplifier circuit shown in Fig. is biased at $I_C = 1\text{mA}$. Use $V_T (= kT/q) = 26\text{mV}$, $\beta_0 = 200$, $r_b = 0$ and $r_o \rightarrow \infty$

- Determine the ac small-signal midband voltage gain v_o/v_i of the circuit.
- Determine the required value of C_E for the circuit to have a lower cut-off frequency of 10 Hz.

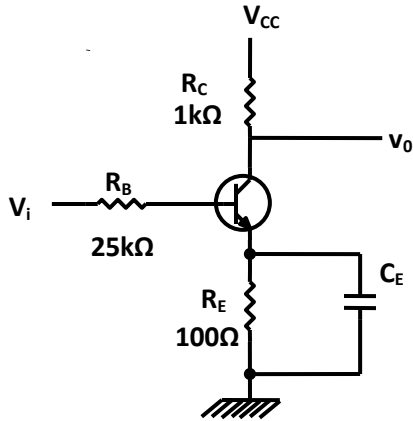

20. A simple active filter is shown in Fig. Assume ideal op-amp. Derive the transfer function v_o/v_i of the circuit, and state the type of the filter (i.e., high-pass, low-pass, band-pass, or band-reject). Determine the required values of R_1 , R_2 and C in order for the filter to have a 3-dB frequency of 1 kHz, a high-frequency input resistance of 100 k Ω , and a high frequency gain magnitude of 10.

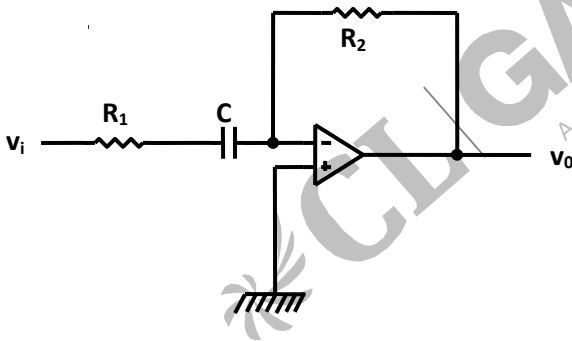

21. A voltage commutated thyristor chopper circuit is shown in Fig. The chopper is operated at 500 Hz with 50% duty ratio. The load takes a constant current of 20A.
- Evaluate the circuit turn off time for the main thyristor Th_1 .
 - Calculate the value of inductor L , if the peak current through the main thyristor Th_1 is limited to 180% of the load current.
 - Calculate the maximum instantaneous output voltage of the chopper.

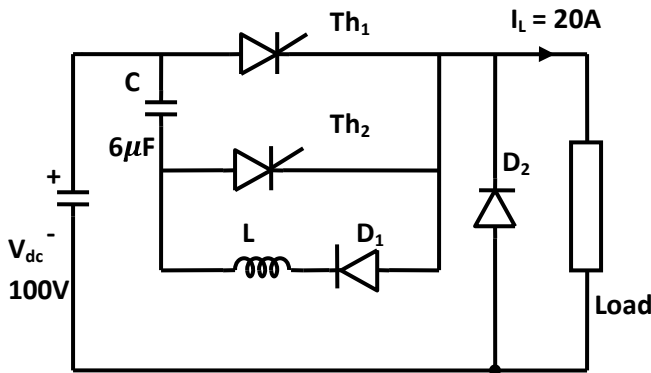

22. A separately excited dc motor is controlled by varying its armature voltage using a single phase full-converter bridge as shown in Fig. The field current is kept constant at the rated value. The motor has an armature resistance of 0.2Ω , and the motor voltage constant is $2.5 \text{ V}/(\text{rad}/\text{sec})$. The motor is driving a mechanical load having a constant torque of 140 Nm . The triggering angle of the converter is 60° . The armature current can be assumed to be continuous and ripple free.
- Calculate the motor armature current
 - Evaluate the motor speed in rad/sec .
 - Calculate the rms value of the fundamental component of the input current to the bridge.

